

SL 350



FROZEN DICE



Self-contained ice maker up to 158 kg - Sprayer system 158 kg 製冰機



● Position n°

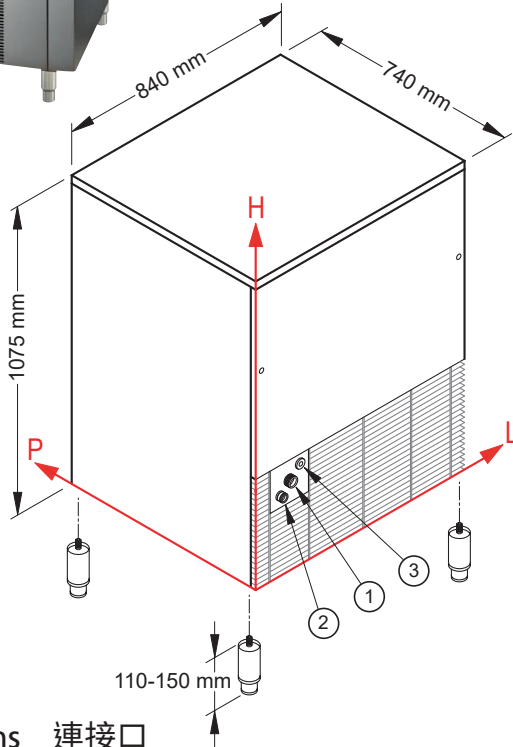

● Connections 連接口

All measures are referred to the rear bottom-left corner (L-H-Ø)
從背面左下起計 (L-H-Ø)

- ① Water inlet: 入水
141 mm - 290 mm - 3/4"
- ② Water outlet: 出水
79 mm - 245 mm - 24 mm
- ③ Electrical connection: 電源
186 mm - 326 mm

● Prod. 24h 24小時產量

Air temp.	Water temp.	Prod. 24h kg
氣溫	水溫	24小時產量
10°C	10°C	158
21°C	15°C	155
32°C	21°C	132

● Application fields 適用於

Hotel 酒店	●●●●●●●●●●	Fish market 海鮮市場	●●●●●●●●●●
Restaurant 餐廳	●●●●●●●●●●	Supermarket 超市	●●●●●●●●●●
Fast food 快餐	●●●●●●●●●●	SPA 水療	●●●●●●●●●●
Bar 酒吧	●●●●●●●●●●	Medical 醫療	●●●●●●●●●●
Disco 的士高	●●●●●●●●●●	Industry 工業	●●●●●●●●●●

● Working conditions 可接受運作環境

		Min	Max
- Location: Indoor 室內			
Ambient temperature 環境溫度		+10° C	+43° C
Water temperature 水溫		+3° C	+32° C
Voltage 電壓		-10%	+10%
Water inlet pressure 水壓		1bar (14 psi)	6bar (84 psi)

● Technical information 規格

Production in 24h 24小時產量	155 kg
Store capacity, up to 存儲容量	65 kg
Cooling system 冷卻系統	A - W
Kind of cube 冰粒種類	14-17-32-41-60 g
Refrigerant 製冷劑	R452A
Standard voltage 標準電壓	220-240 V ~ 50 Hz
Electrical consumption 耗電量	1400 W
Fuse 保險絲	16 A
Water consumption 耗水量	A: 2.6 l/kg W: 13 l/kg
Sizes (L-P-H mm) 尺寸	840 - 740 - 1075
Sizes with pack (L-P-H mm) 包裝尺寸	880 - 785 - 1245
Net weight 淨重	118 kg
Gross weight 總重	138 kg
Finish 表面	AISI 304 stainless steel, scotch brite 304不銹鋼, 磨沙

● Available dice size 冰粒尺寸

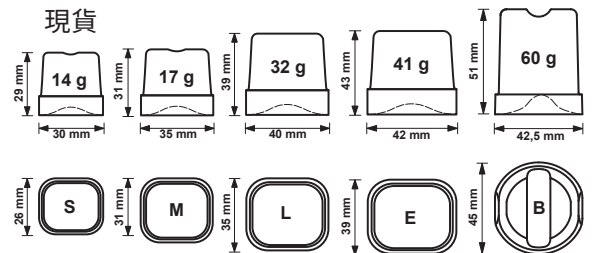

● Certifications available for this model 認證

